

Noviomagus Bone Mill



Today's technology guarantees high quality chips

High quality construction

The Noviomagus Bone Mill is unique because of its superior design and manufacturing. It only consists of few parts, a.o.: a housing, milling drums, a push block and a handle. The housing of the Noviomagus Bone Mill is made of a casted stainless steel alloy, which makes it an extremely solid device. There is no risk for abrasion. Additionally, the milling drums are made of a special hardened stainless steel alloy. Even in case of frequent use they do not show signs of wear. This combination guarantees a high quality graft without metal contamination.

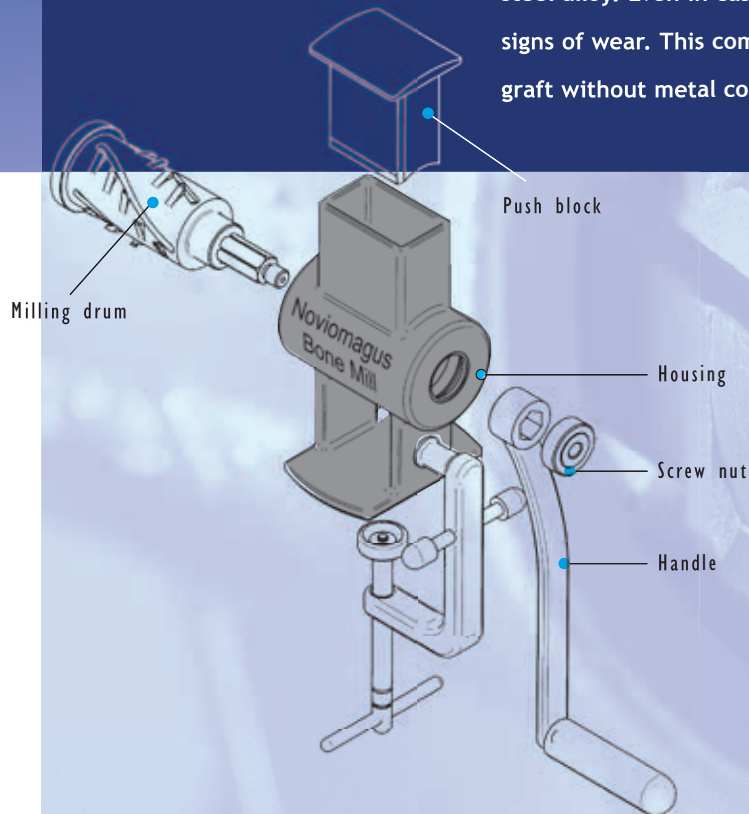

Mills fresh frozen bone

The teeth of the milling drums feature a unique technology. They are spirally positioned and razor sharp. Because of this unique and patented design, the Noviomagus Bone Mill is easy to handle and optimal in use. It can mill a femoral head in less than 30 seconds and can mill fresh frozen bone with equal ease, which avoids the risk of defrosting too much bone prior to surgery. This results in time- and money-saving efficiency during surgery.

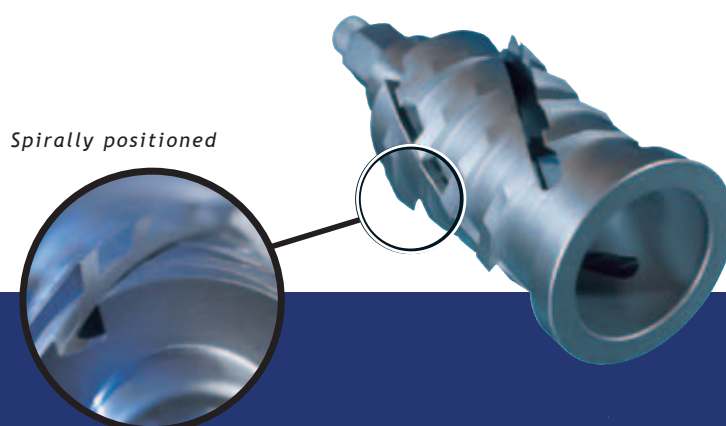

Bone chips with intact trabecular structure

There are six milling drums available for different surgical applications. The *Extra Extra Extra Fine* drum produces mini chips. The *Extra Extra Fine* and *Extra Fine* drum are designed to produce extra small bone chips for spinal grafting and the filling of small defects.

For impaction bone grafting procedures in hip revision surgery it is necessary to use grafts with a trabecular structure. All drums of the Noviomagus Bone Mill guarantee grafts with an intact trabecular bone structure, because it breaks out grafts. The Fine milling drum is designed to produce small grafts for distal femoral grafting. The Coarse and Extra Coarse milling drums are designed to produce large grafts for respectively proximal femoral and acetabular grafting.



Less than 30 seconds!



Advanced benefits

- Bone chips with intact trabecular structure
- Milling of a femoral head takes less than 30 seconds
- Mills fresh frozen bone
- 5 year guarantee for hospital use
- Six types of milling drums for each type of indication
 - Extra Extra Extra Fine
 - Extra Extra Fine
 - Extra Fine
 - Fine
 - Coarse
 - Extra Coarse
- No risk of metal abrasion
- Long life-span without wear
- Easy to clean

Today's technology guarantees high quality chips

Ordering information

Noviomagus Bone Mill

Noviomagus Bone Mill:	
Housing	SBM-9801-02
Push Block	SBM-9801-05
Handle	SBM-9801-06
Screw Nut	SBM-9801-07
Sterilization Tray Bone Mill	SBM-0808-10
Noviomagus Milling Drum Extra Extra Extra Fine	SBM-1209-59
Noviomagus Milling Drum Extra Extra Fine	SBM-0604-09
Noviomagus Milling Drum Extra Fine	SBM-9801-08
Noviomagus Milling Drum Fine	SBM-9801-03
Noviomagus Milling Drum Coarse	SBM-9801-04
Noviomagus Milling Drum Extra Coarse	SBM-0903-11
Milling Drum Sterilization Tray (NBM)	SBM-1303-61

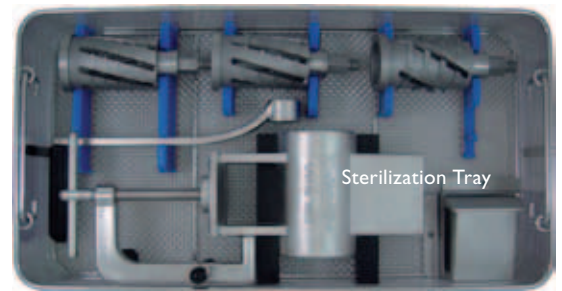

The Noviomagus Bone Mill is CE marked and FDA approved. US Patent No. 6,318,651.

No rights can be derived from the information in this brochure.

Other Noviomagus products manufactured by Spierings Orthopaedics B.V. are: Noviomagus Impactor Set, Noviomagus Revision Meshes, Noviomagus Femoral Head Reamer Set and Noviomagus Mini Mill.

Copyright: Spierings Orthopaedics B.V.

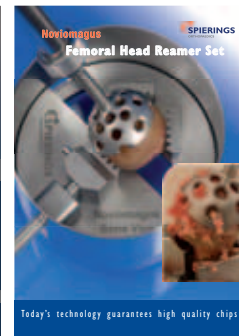

Manufactured by:
 Spierings Orthopaedics B.V.
 Madoerastraat 24
 6524 LH Nijmegen
 The Netherlands
 T: +31 -(0)24-3501603
 F: +31 -(0)24-3501604
 E: info@spierings.biz
 I: www.spierings.biz